



Table of Contents

About this Manual	3
1. Safety Instructions	4
2. Product Description	4
2.1.1 External solar optimizer	4
2.1.2 Connector of external solar optimizer	5
2.2 Composition of photovoltaic system ..	11
3. System Installation Instructions	11
3.1 Preparation of tools	11
3.2 Instructions to installation steps	12
4. Check and Replacement	15
4.1 Check.....	15
4.2 Replacement.....	15
5. Instructions to Applicable Scene	16
5.1 One MPPT port with one string	16
5.1.1 Full installation	16
5.1.2 Installation of mismatched modules	17
5.2 One MPPT port with multiple strings	18
5.2.1 Full installation	18
5.2.2 Installation of mismatched string	18
5.2.3 Installation of mismatched module	19
6. Appendix	20
6.1 Product Specification	20

About this Manual

This Manual is mainly for the SP-1-0 solar power optimizer.

➤ Purpose

The purpose of this Manual is to provide readers with the product's detailed information and installation, operation and maintenance instructions.

➤ Reader orientation

This Manual is suitable for professional technicians and users who install, operate and maintain the external solar optimizer.

➤ Use of manual

Read this manual carefully before using this product and keep it in a place where operation and maintenance personnel can find it easily.

➤ Use of symbol

The following symbols may be used in this Manual, please read them carefully for better use of this Manual.



"Danger" indicates a situation that has a high potential risk and will result in death or serious injury if not avoided.



"Warning" indicates a situation that has a moderate potential risk and may result in death or serious injury if not avoided.



"Caution" indicates a situation that has a low potential risk and may result in moderate or minor injury if not avoided.



"Attention" indicates a situation that has a potential risk and may result in equipment failure or property loss if not avoided.

1. Safety Instructions

To ensure the safe installation and operation of optimizer and reduce the risk of electric shock and equipment damage, the following safety precautions shall be strictly followed during operation and maintenance.

 **Warning**

All installation operations must be completed by professional technicians. The professional technicians must:

- (1) Undergo specialized training;**
- (2) Read this Manual completely and master the operation-related safety matters;**
- (3) Be familiar with relevant safety specifications of the electrical system.**

2. Product Description

2.1.1 External optimizer

SP-1-0 external optimizer mainly has optimization + long string of voltage limiting + no hot spot and other functions, with the following characteristics:

- Eliminate current mismatch and recover power generation loss based on SLM6120 power optimization chip
- Suitable for all types of modules
- Solve the mismatch caused by barrier, dust accumulation, snow accumulation, orientation difference, attenuation difference and double-sided power generation
- Optimize power generation, reduce LCOE, improve system reliability and extend service life of module

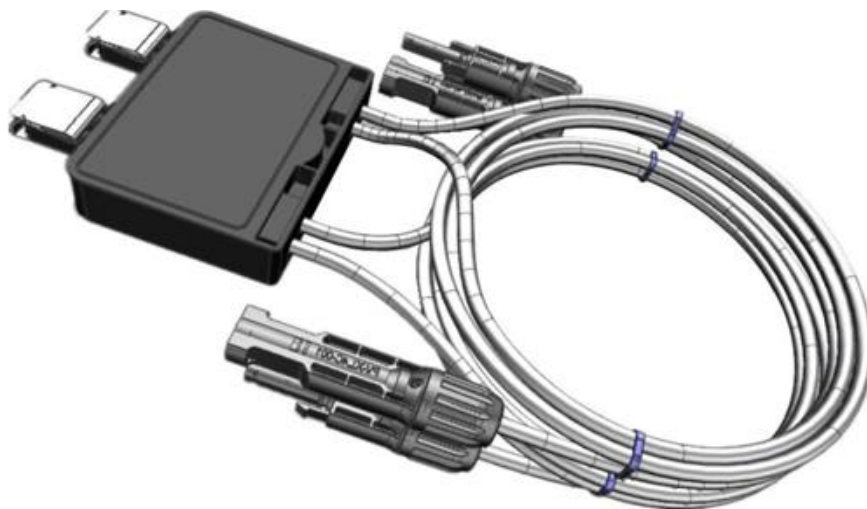

2.1.2 Connector of external optimizer

The functions of connector for SP-1-0 external optimizers (photovoltaic systems) are reflected in all links of photovoltaic connection, mainly used in junction box of photovoltaic module terminal, photovoltaic inverter, photovoltaic combiner box and electrical connection of photovoltaic power station array. SP-1-0's photovoltaic connector is derived from MC4 connector. To meet the requirements of TUV creepage, the corresponding adjustments have been made to form "PV-XL4C-OO 1" connector for photovoltaic systems.

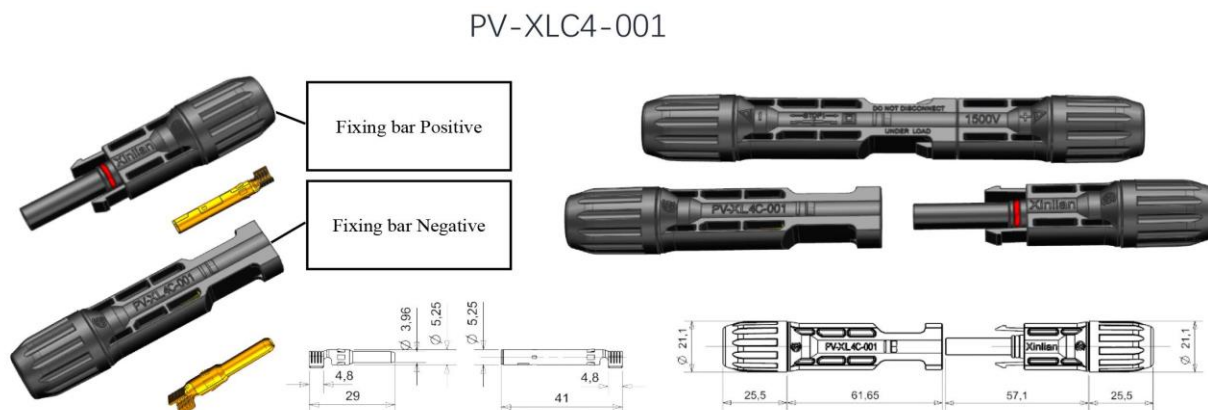

2.1.2.1 Technical data

Technical Data			
Rated voltage	1500V DC per CSA 6703 1500V DC per TÜV IEC62852	Cable OD range	Ø5.3mm –Ø7.65mm
Rated current (per TUV 62852, 85°C)	30A (4.0mm ² /12AWG) per TUV 6703 35A (4.0mm ² /12AWG) per CSA 6703	Ingress protection rating	IP68, mated (1 m, 1 h) & IP2X touch-proof, unmated
Rated impulse voltage	12kv (1500V DC per TÜV/CSA)	Ambient temperature range	-40°C to +85°C (TÜV) -40°C to +90°C (CSA)
Typical contact resistance	≤0.3mΩ	Upper limiting temperature	+120°C
Contact material	Tin-plated Copper Alloy	Flame class	TÜV /CSA 94 V-0
Contact system options	Cold Formed (CF) or Stamped & Formed (S&F)	Overvoltage category/Pollution degree	CAT III/2
Type of termination	Crimping	Material safety	RoHS, REACH compliant
Insulation material	PC-9330 Sabic PPE+PS, PX9406P(C)(F1) Sabic	Approvals	TÜV certified to IEC 62852 CSA certified to CSA 6703

2.1.2.2 Tools



Wire stripper



Crimping plier



Spanner

2.1.2.3 Wire stripping

Strip the cable end with a wire stripper with the stripping length of $7.0 \pm 1.0\text{mm}$, without fracture of copper wire.

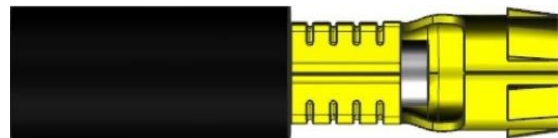

2.1.2.4 Connector crimping

Place the U-shaped part of positive (or negative) pin on the jaws of crimping plier, then place the stripped cable on the U-shaped part of positive (or negative) pin to the end, attach the wire sheath to U-shaped opening, press it with crimping plier until the crimping plier can be released freely.

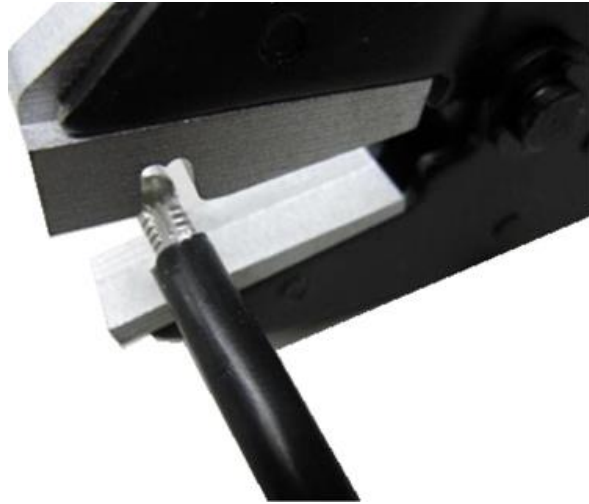

2.1.2.5 Pin assembly

Insert the positive pin into the positive plastic part (insert the negative pin into the negative plastic part). After hearing the sound of "click", it will not be pulled out by gentle force, it can rotate half a circle clockwise without obstruction and rotate in place freely and smoothly.

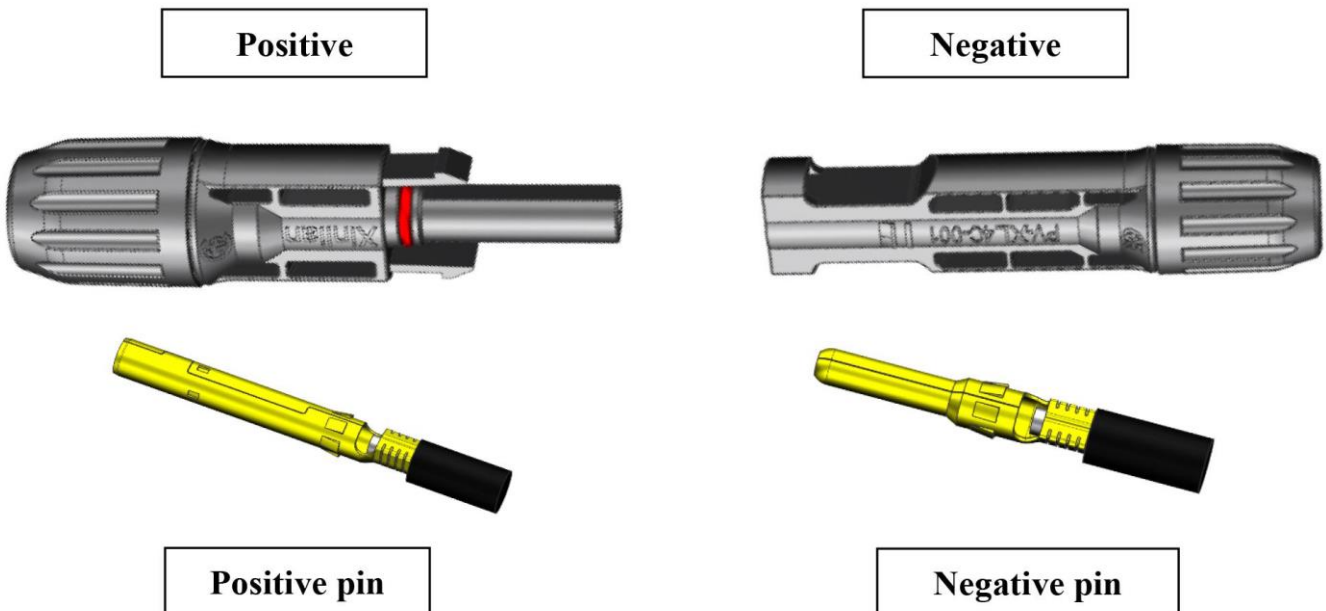

2.1.2.6 Assembly of positive plug-in

Fix the positive pole and pressurized cover with two spanners respectively; use the spanner to rotate pressurized cover clockwise to tighten it with a torque of 2-3Nm (tightening torques vary with types of cable).



2.1.2.6 Assembly of negative plug-in

Fix the positive pole and pressurized cover with two spanners respectively; use the spanner to rotate pressurized cover clockwise to tighten it with a torque of 2-3Nm (tightening torques vary with types of cable).



2.1.2.7 Matters needing attention

- One-step installation. The nut shall not be loosened in the reverse direction unless required for maintenance. After loosening, it must be re-tightened to the torque of initial installation.
- Alkane substances are prohibited from contacting connectors, such as gasoline, cleaning lubricant, electronic revivifier and other solvents containing alkanes.
- Handle products gently during loading, unloading and transportation. Avoid making it under external pressure to avoid damage.
- When installing the junction box and connector, confirm that the battery pack is not in operating state. The human body shall not contact the positive and negative terminals at the same time, so as to avoid electric shock and electrostatic breakdown diode of the human body.
- Under any circumstances, the positive and negative plugs of the same set of junction box connectors cannot be plugged together to prevent the bum of battery panel due to short circuit of positive and negative poles.
- If not for maintenance, do not open and close or plug and unplug the connection system frequently, which will reduce the waterproofness, sealing and service life.

2.1.2.8 List of chemicals to avoid direct contact

Substance	Influence
Gasoline	Avoid direct contact or seal it in a confined space, which may cause slight peeling on the surface of junction box
White flower oil	Avoid direct contact or seal it in a confined space, which may cause crack or fracture of junction box
Pain ease oil	Avoid direct contact or seal it in a confined space, which may cause crack or fracture of junction box
Acetone	Avoid direct contact or seal it in a confined space, which may cause crack or fracture of junction box
Essential balm	Avoid direct contact or seal it in a confined space, which may cause crack or fracture of junction box
Bonesetting liquid	Avoid direct contact or seal it in a confined space, which may cause crack or fracture of junction box
Banana oil	Avoid direct contact or seal it in a confined space, which may cause crack or fracture of junction box
Release agent (such as Pelicoat)	Avoid direct contact or seal it in a confined space, which may cause crack or fracture of junction box
Adhesive glue or potting glue that can produce oxime gas (such as KE-200, CX-200, Chemlok)	Avoid direct contact or seal it in a confined space, which may cause crack or fracture of junction box
TBP (plasticizer)	Avoid direct contact, which may cause crack or fracture of junction box
Oil (such as KV46)	Avoid direct contact, which may cause crack of junction box
Mold temperature oil	Avoid direct contact, which may cause crack of junction box
Ethyl alcohol	Avoid direct contact, which may cause slight peeling on the surface of junction box
Grease (such as Molykote)	Avoid direct contact, which may cause crack or fracture of junction box
Cleaning agent	Avoid direct contact, which may cause crack or fracture of junction box

2.2 Composition of photovoltaic system

The difference between the photovoltaic system installed with external optimizer and the ordinary photovoltaic system is that each photovoltaic module is installed with an external optimizer to achieve module-level MPPT. The input of external optimizer is connected to output of module. The output of optimizer replaces the output of module in series to form the string, which is merged into later stage inverter or combiner box.

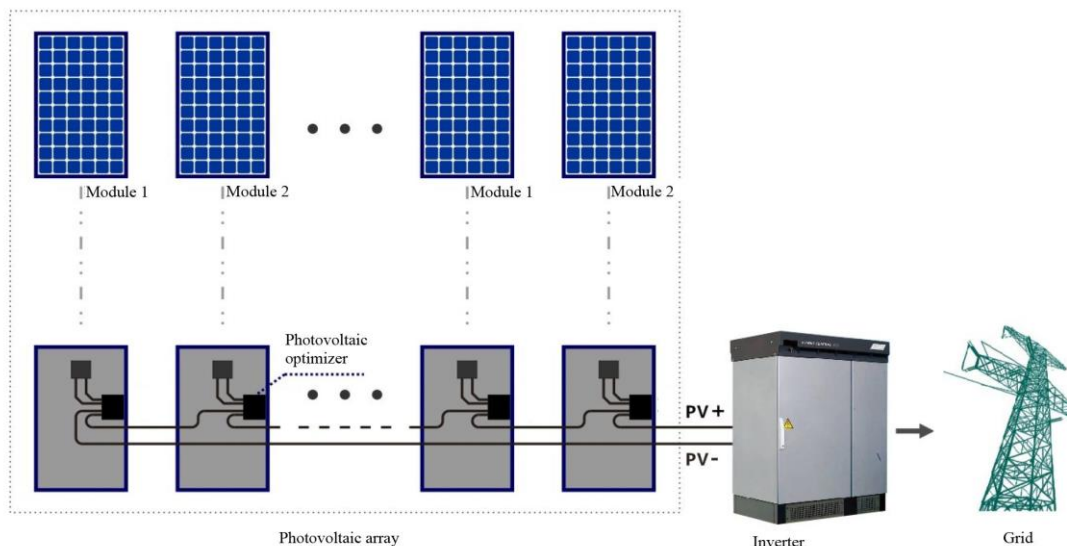



3. System Installation Instructions

3.1 Preparation of tools

The following tools will be used for installation, check and replacement:

<p>Cross screwdriver (cross pattern-M4)</p>	<p>Multimeter (maximum voltage range of 1500Vdc)</p>

	
Clip-on ammeter (maximum current range of 100A _{dc})	MC4 connector spanner

3.2 Instructions to installation steps



Warning

Read all instructions and warnings of this Manual and warning signs on inverter and module array before installation.



Warning

Shut down the inverter and disconnect it from module array before installation.



Warning

Before installation, confirm that the output current, voltage and power of photovoltaic module are matched with external photovoltaic optimizer.

Step 1. Shut down the inverter and disconnect it from module array.

Before the installation of optimizer, make sure that inverter is shut down and disconnected from the module array.

Step 2. Install the optimizer to module frame.

Place the external optimizer into module frame in the direction shown in the figure, clip the buckle into module frame directly.



Step 3. Connection of input line

The line marked with "IN" on the housing of external optimizer is the input line, which is connected to the output line of module.

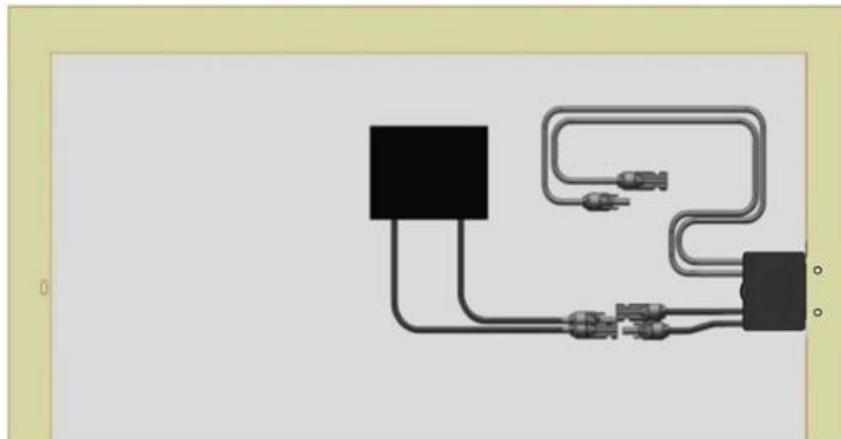



Attention

**When installing, connect the input line of optimizer first, then connect the output line.
When removing, disconnect the output line first, then disconnect the input line.**

Step 4. Connect output lines to form string

After connecting the input lines, connect the output lines in series to form a string. The positive and negative connectors of string shall be connected to the later stage inverter or combiner box.

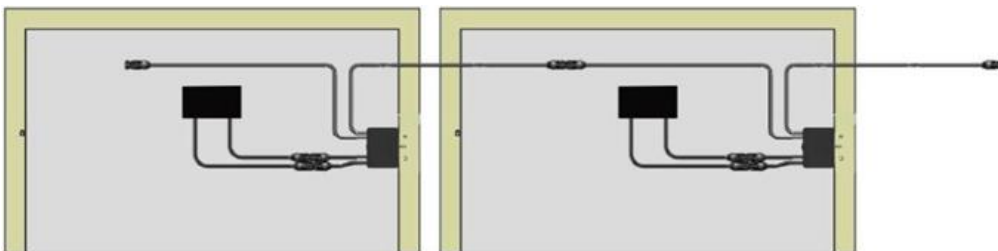

Step 5. Merge the string into inverter

After confirming that the entire string is connected correctly, merge the string into the later stage inverter or combiner box.

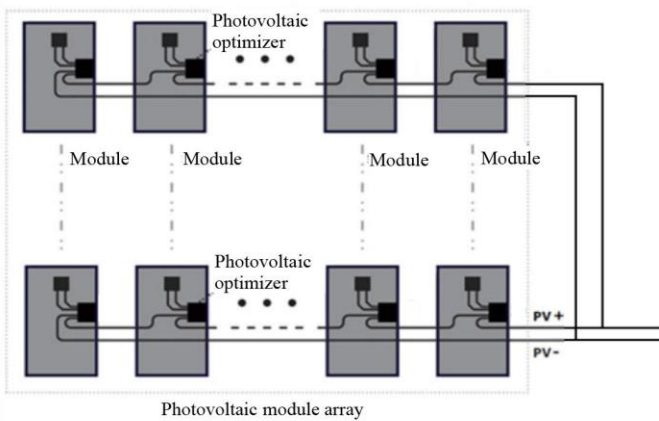

System Architecture Diagram



Photovoltaic grid-connected inverter



Grid

Step 6. Turn on the inverter

After confirming that the system is connected correctly, tum on the inverter.

4. Check and Replacement



Warning

The following operations must be completed by trained professional technicians to avoid the risk of electric shock.

4.1 Check

Check whether the optimizer is abnormal by following the steps below:

- (1) To check whether the external optimizer is operated normally , measure the input current of optimizer with clip-on ammeter. If there is input current, the optimizer is operated normally; if the input current is 0, the optimizer or module is abnormal.
- (2) If the input current is 0, check whether the module is obviously damaged or seriously blocked. If it is obviously damaged, replace the module; if it is seriously blocked , remove the block.
- (3) If module is normal, check the connected cables for disconnection. After disconnecting the input line of optimizer (the output line is disconnected first), measure the voltage of positive and negative connectors of module output line with a multimeter. If the voltage is normal, the line connection is normal; if there is no voltage, check the line connection further to confirm the open-circuit contact.
- (4) If the module and line connection are normal, the replacement of optimizer shall be considered.

4.2 Replacement

Replace the optimizer by following the steps below:

- (1) Shut down the inverter and disconnect it from corresponding string.
- (2) Disconnect the output line of optimizer.
- (3) Disconnect the input line of optimizer.
- (4) Remove the original optimizer and install the new one.
- (5) Connect the input line.
- (6) Connect the output line.
- (7) Connect the corresponding string to the later stage inverter.
- (8) Restart the inverter.
- (9) Test the input current of replaced optimizer with a clip-on ammeter to confirm repair.

5. Instructions to Applicable Scene

The external optimizer is suitable for various types of power stations, distributed and large-scale surface power stations; new power stations, reconstructive old power stations. In consideration of various mismatch situations, the installation methods are as follows.

5.1 One MPPT port with one string

5.1.1 Full installation

The photovoltaic system has various mismatches, such as shadow shading, inconsistent orientation, inconsistent aging, stain, glass fragments, ash accumulation, snow accumulation. It can be said that there is no system without mismatch. The difference lies in the mismatch.

The full installation can solve various series (current) mismatch and recover losses caused by mismatch to the full extent.

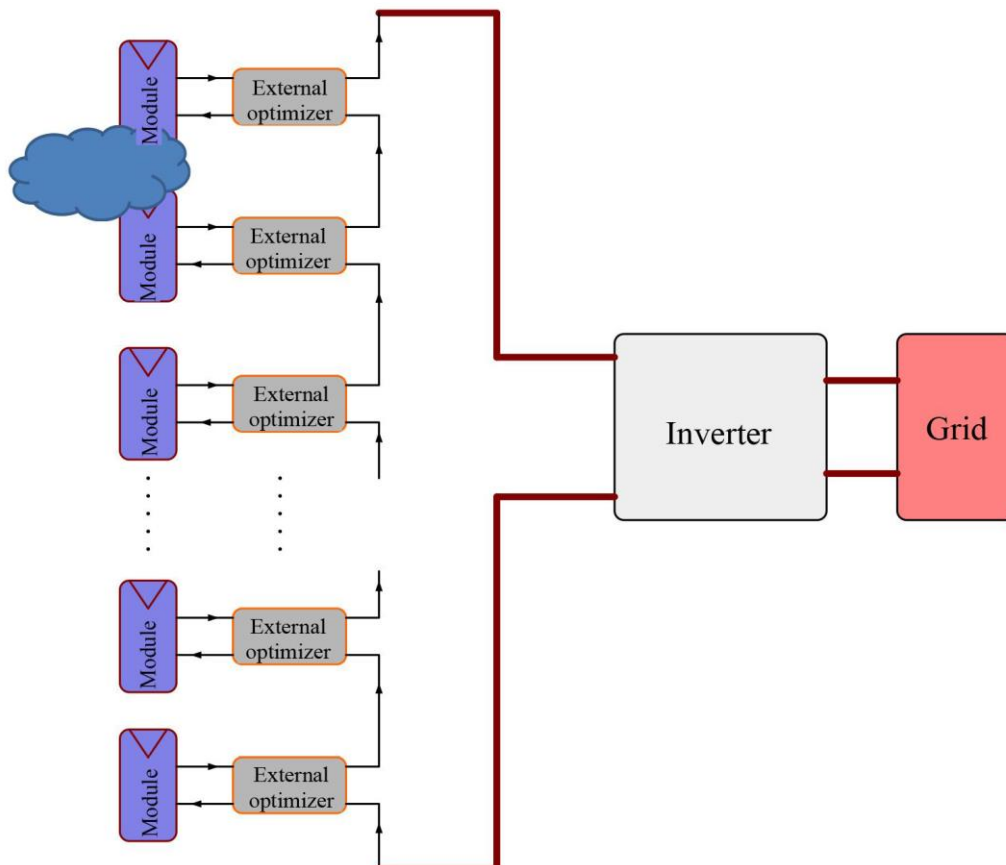

5.1.2 Installation of mismatched modules

If the mismatched modules of system are clear, it can be considered to install only on mismatched modules or solve series mismatch to save costs.

Instructions for installing mismatched modules:

- If module has the clear mismatch, such as shading, low effective illumination caused by orientation deviation, install on the module with clear mismatch.
- If the current value of module with low current in string is different due to the reconstruction and replacement of the old power station, install on the module with small current values.

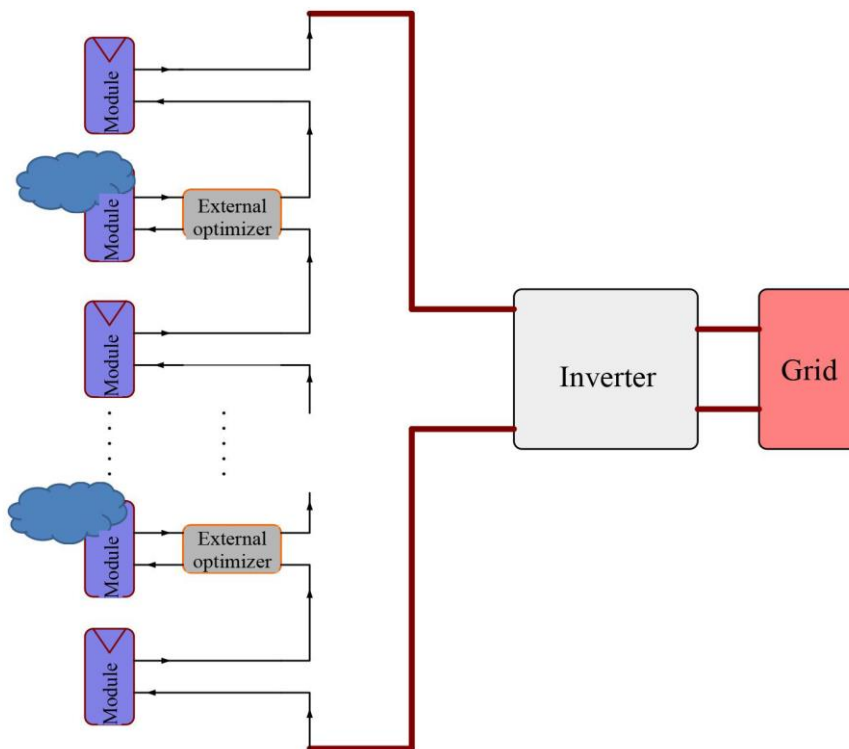

Risk of installation on mismatched module only:

- The mismatch of other modules cannot be solved. When the judgment of system mismatch is not accurate, for example, some modules are seriously mismatched due to damage while there is no obvious mismatch on the surface, because the optimizer is not installed, this module will cause great loss to the power generation of system.
- The mismatch is not fixed and will change with time, environment and conditions. If the installation is based on current mismatch, the mismatch changes after a period of time, the mismatch cannot be solved effectively.

5.2 One MPPT port with multiple strings

5.2.1 Full installation

If one MPPT port of the photovoltaic system has multiple strings, there will be series mismatch and parallel mismatch in the system. The most effective method is full installation.

The full installation in array corresponding to one MPPT port can solve series (current) mismatch and parallel (voltage) mismatch to recover losses caused by mismatch to the full extent.

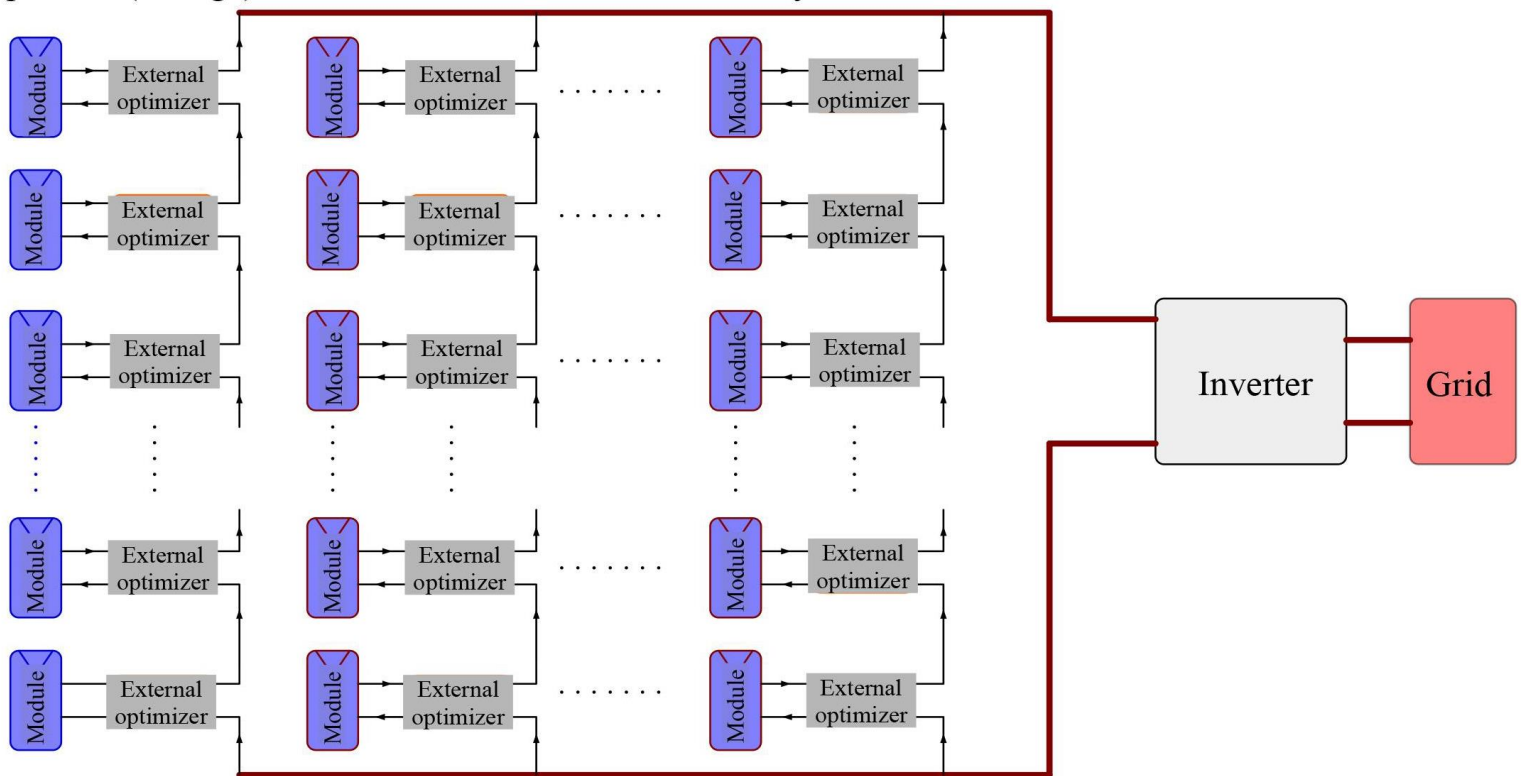

5.2.2 Installation of mismatched string

When only part of strings in one MPPT port array has clear mismatch and other strings have no obvious mismatch, it is allowed to install the mismatched strings only. In this way, the series mismatch in this string can be solved and the losses of power generation can be recovered to a certain extent, but the parallel mismatch cannot be solved.

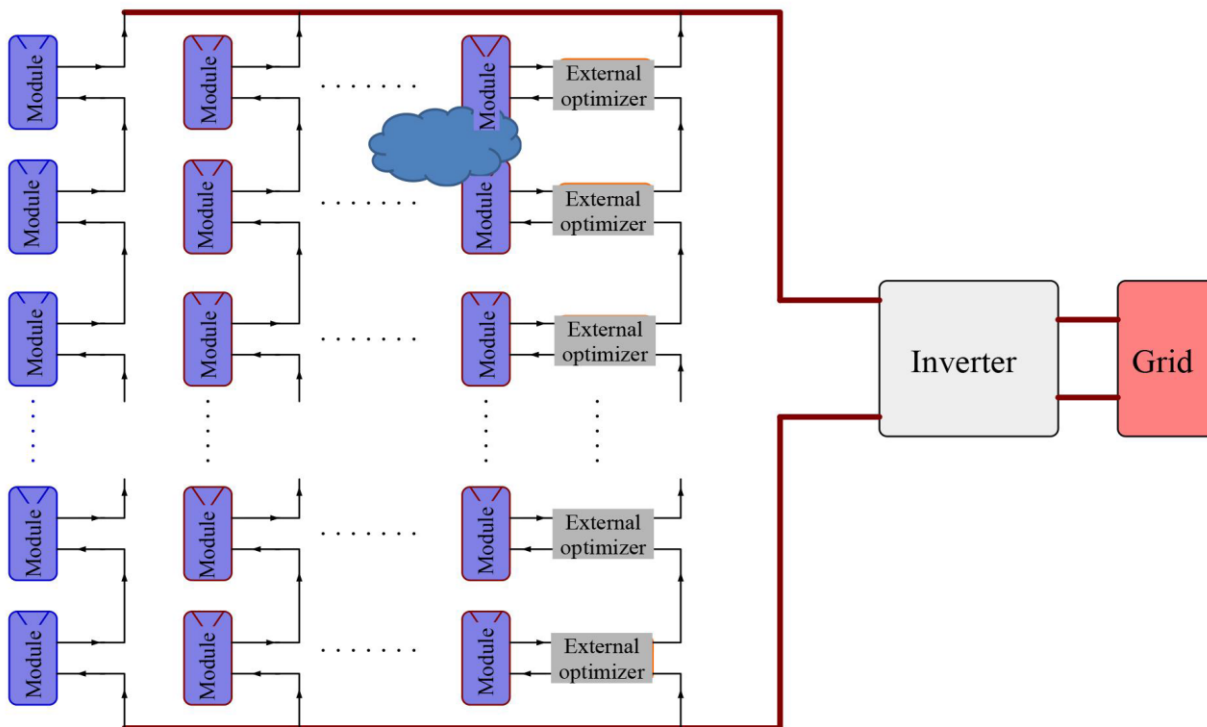

5.2.3 Installation of mismatched module

When only part of modules in an array has clear mismatch, it is allowed to only install the modules with clear mismatch. In this way, the mismatch can be solved to a large extent at the lowest cost, so as to recover losses of power generation.

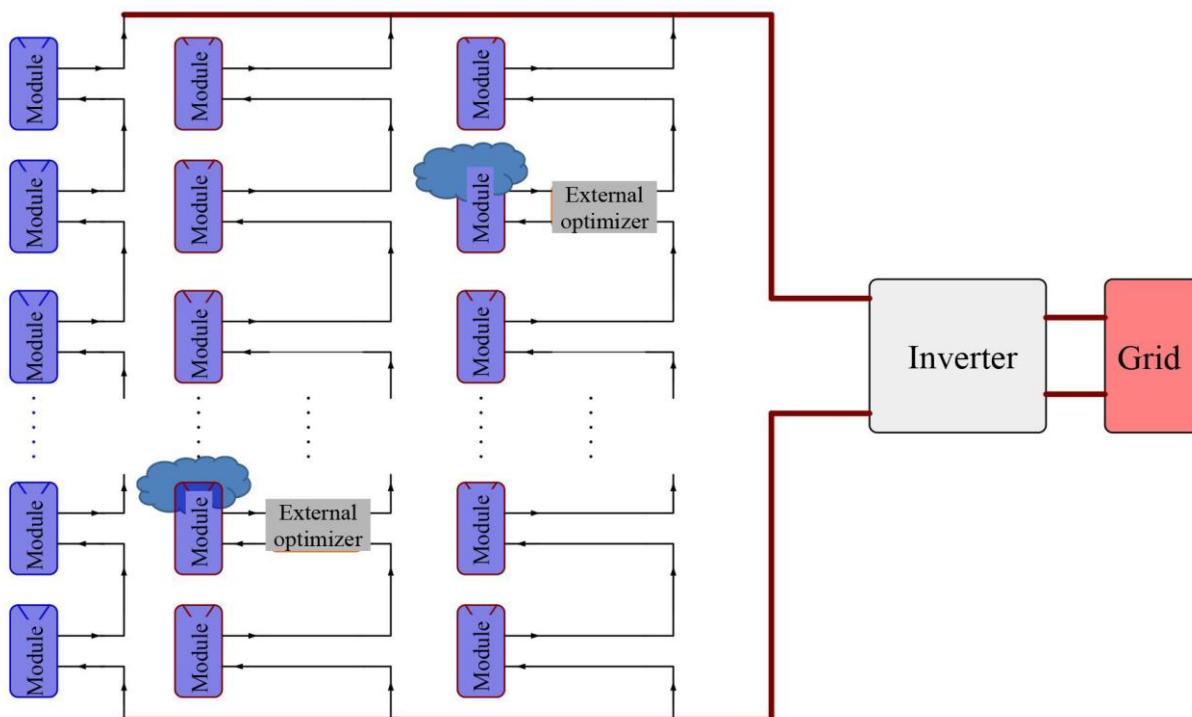

6. Appendix

6.1 Product Specification



Product name: Solar Power Optimizer					
Technical Data					
Input parameters	Maximum input power	600W	Conversion efficiency	Peak conversion efficiency	99.59%
	Operating voltage range	3~70V		Power consumption @5A	0.9W
	MPPT voltage range	8~70V		Power consumption @8A	1.4W
	Maximum input current	15A/upgradeable		Power consumption @12A	2.9W
	Over-current protection value	18A		Power consumption @15A	3.8W
	Over-temperature	160°C		Dimension	106*105*22mm
Output parameters	Maximum output current	15A	Installation specification	Weight	570g
	Theoretical maximum output voltage	65V		Cable	4mm ²
	Output voltage limit value	40V/adjustable on demand			70cm*2 input
	Maximum system voltage	1500V			100cm*2 output
	72 type module in series @1500V	37-piece module		Connector	PV-XLC4-001
	72 type module in series @1100V	27-piece module		Operating temperature	- 40°C- +85°C
	72 type module in series @1000V	25-piece module		Protection rating	IP68
Design standards	Designed life	30-year	Function	Standard items	Optimization/ long string of voltage limiting/ no hot spots